



# AFS 400

## 50'-80' Tilt-Up Pole



# Table of Contents

Recommended Tools/Equipment List .....	1
Bill of Materials .....	2-3
Installation Instructions .....	4-10
Torque Specifications .....	11

Proprietary rights are included in the information disclosed herein. This information is submitted in confidence and neither the document nor the information disclosed here-in shall be reproduced or transferred to other documents for manufacturing or for any other purpose except as specifically authorized in writing by ARE Structures.

# Tools/Equipment List

## Wrenches/Ratchets:

- Wrench Set
- 8" Pipe Wrench
- 20mm+ Crescent Wrench
- 56mm+ Crescent Wrench
- 1/2" or 3/4" Socket Set
- Socket/Ratchet Universal
- Socket Extensions
- Torque Wrench

## Power Tools:

- 1/2" or 3/4" Impact Driver

## Iron Working Tools:

- 36" Crow Bar
- Adjustable Spud Wrench
- 3# Hammer
- 8" Round Metal File
- 8" Flat Metal File
- 36" Cheater Pipe







## Rigging:

- (2) 8' Nylon Slings
- (4) 3 Ton Shackles



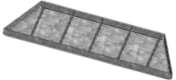

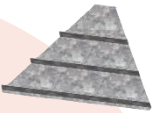
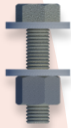
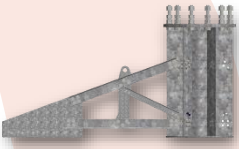
**NOTE:** Tools and equipment lists are suggestions. Required tools/equipment is the responsibility of the installer and will vary depending on installation specifications.

Contact **ARE** at (651) 330-1263 or email: [sales@are-structures.com](mailto:sales@are-structures.com) with questions or set up a training call.

# BILL OF MATERIALS

ITEM	NAME	QTY	ITEM	NAME	QTY
	Kingpost	1		Corner Brackets	6
	Ballast Tray	6		Kingpost Bolts Assey (M36x2.5x225mm Hex Bolt(12); M36. Flat Washer (48); M36 Hex Nut (36))	96
	Ballast Plate	6		Ballast Tray & Diagonal Web Bolts Assey (M16x2.0x60mm/M12x1.75x45mm) Hex Bolt (174/96); Flat Washer (348/192); Nut(174/96)	696/ 384
	Diagonal Web	12		Sidewall	6
	Vertical Web	6			
	Truss Heal Plate & Upper/Lower Chord	30			

## Lift Assist Options: (Sold Separately)

ITEM	NAME	QTY
	15T-20T (2x) Hydraulic Ram	2
	Hydraulic Power Unit (12V)	1
	M64x593 Cylinder Pin	2
	12x75mm Cotter Pin	2

# Bill of Materials Cont'd 50' Tilt-up

Pole Section #4 - Qty. 1  
372 lbs. (169kg)  
5.185m (17')



Pole Section #3 - Qty. 1  
486 lbs. (221kg)  
4.156m (13.64')



Pole Section #2 - Qty. 1  
862 lbs. (392kg)  
4.235m (13.9')



Pole Section #1 - Qty. 1  
689 lbs. (313 kg)  
0.805m (2.64')

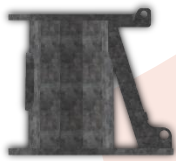

# Installation Instructions

## Kingpost:



Kingpost

1. Level the ground base of the site location using aggregate or gravel to ensure a stable and even surface.
2. Align Outrigger Leg segments with the Kingpost using M36x2.5x225 and M16x2x60 hex bolts. Carefully thread the bolts through the Outrigger Leg segments to prevent damage to the hex bolts (3a-b).



M36x2.5x225mm Hex Bolt with M36 washer

3. Connecting the Outrigger Leg segment to Kingpost with M36x2.5x225mm hex bolts.

Repeat process multiple times (6x) to attach the Outrigger Legs (6x), Ballast Trays (6x), Ballast Plates (6x), Sidewalls (6x) and Kingpost (1x).

3a.

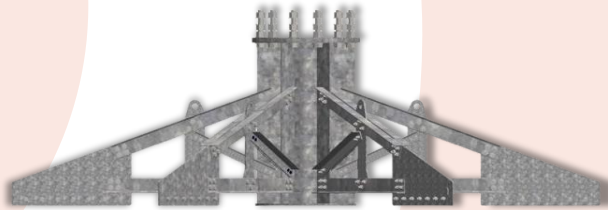

3b.

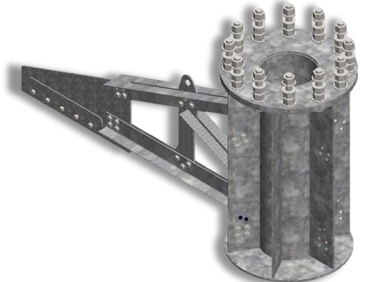

Position the central Kingpost on the level surface and arrange the Ballast Trays & Ballast Plates evenly around it throughout the circumference using washers and nuts respectively.

4. Place Ballast Plate to the Ballast Tray and Diagonal Leg segment with M36 hex bolts using the previous steps.

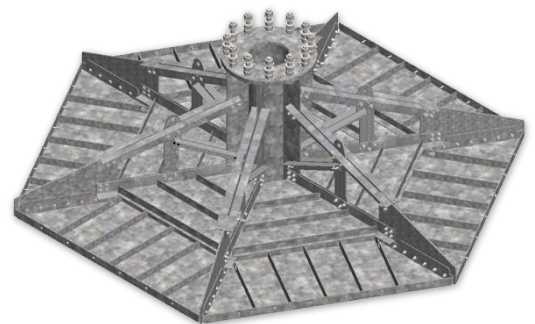
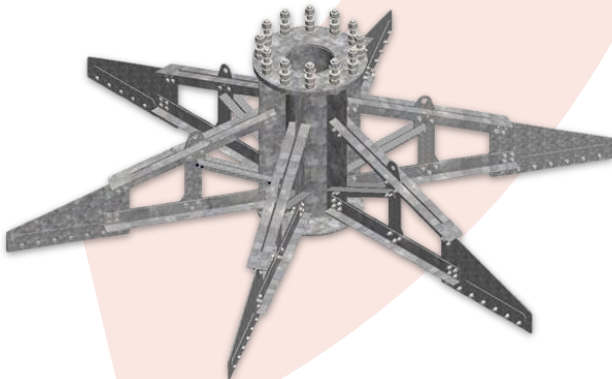

5. Add M36 flat washer and M36 hex nut to the end of M36 hex bolt and tighten to secure the segments.

6. Once legs, trays and plates are bolted, tighten bolts using the star pattern method. Tighten all bolts to torque specifications provided on Pg. 11 of this installation manual.

## Ballast Trays, Plates & Diagonal Leg Segments:

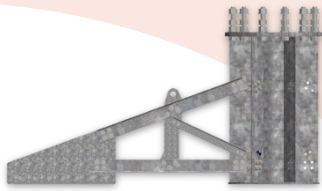

Kingpost with Diagonal  
Brace Segment

7. Insert M36x2.5x225, M16x2x60 hex bolt and M36, M16 flat washer to connect the Kingpost with the Diagonal Brace segment attaching Sidewalls, Ballast Tray and Ballast Plates to Upper Chord. Complete bolt attachment with M36&M16 flat washer and hex nut.

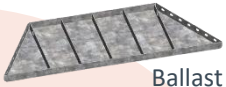

Ballast Tray

8. Diagonal Braces and Diagonal Web are to be fixed to the vertical Hinge Post connected across the Upper Chord Round Pipe to the main Kingpost. Sidewalls are to be attached to the Outrigger Legs.

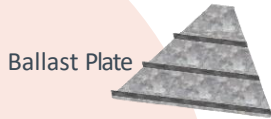

Ballast Plate

9. Connect the Ballast Tray (6x) and Ballast Plates (6x) to the Kingpost using the M16/M12 hex nut and flat washers, respectively, using the above process.

10. Assemble the Outrigger Legs with the Ballast Tray using M16/M12 bolts connecting the Truss Heel Plates with the chords & web.

Assemble the sidewalls & tighten the bolts so all the steel is in contact with each joint.

Tighten all bolts to torque specifications provided on Pg. 11 of this installation manual.

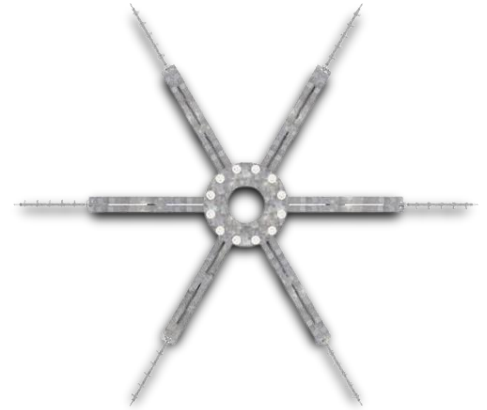

## Foundation with Walls and Ballast Blocks:

1. Assemble the Ballast Trays (6x), Ballast Plates (6x) Diagonal Leg segments (6x) with Sidewalls (6x) connecting to Kingpost. Complete the attachment using M12, M16 & M36 flat washers and hex bolts.
2. Wherever necessary, fasten the sidewalls with Clevis & Cotter pins.
3. Fill the foundation with the ballast.

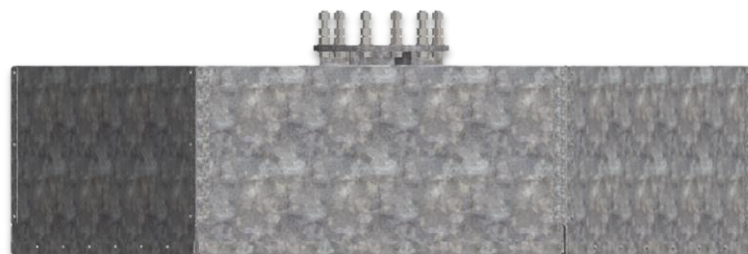
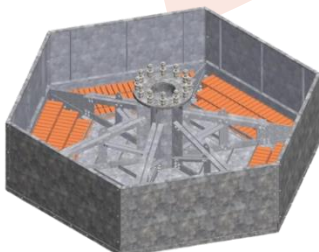
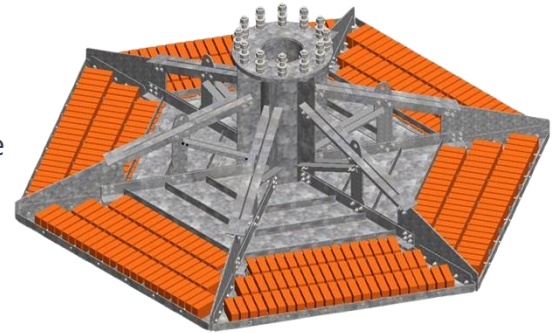

154.3\"(3.919.5m)

43.94\"  
(1.116m)

# Tower Assembly:

On the Kingpost Flange Plate, add M36 nuts and washers. Cylindrical Brackets to be added and secured with M36 flat nuts & washers.

11. Position the hydraulic ram onto the Kingpost and fasten it firmly using M15 bolts. Pin the hydraulic ram to the bottom bracket and anchor the first pole segment to the Kingpost, which connects it to the hydraulic ram at the top end.

13. Forming a hinge, pin the second segment of the pole. Keep the pole horizontal and secure it to the hydraulic ram's top.

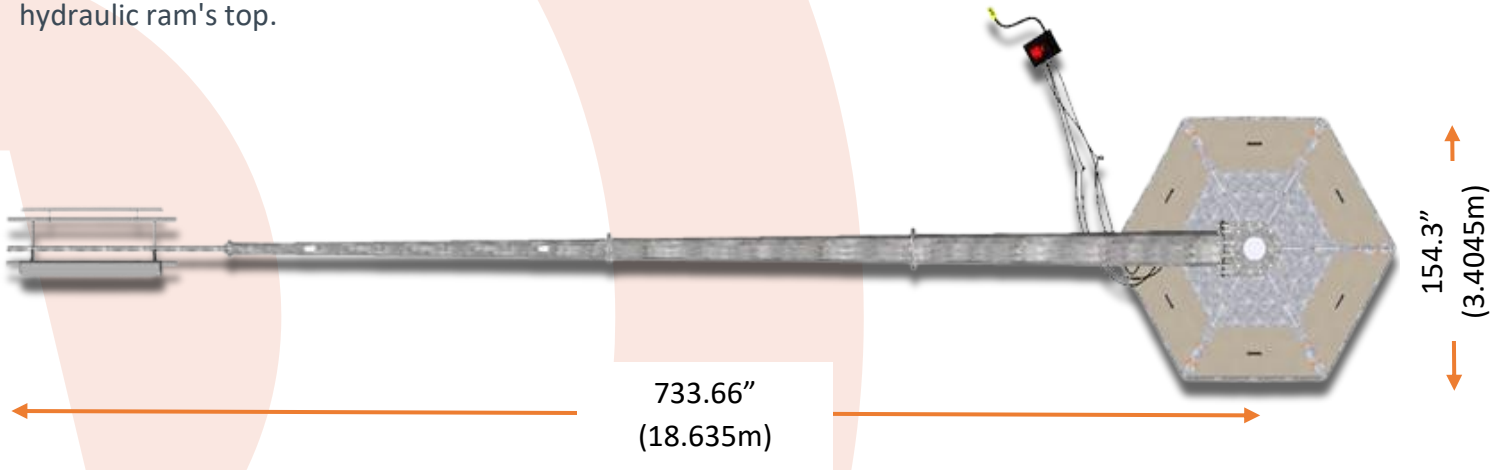

**NOTE:** Ensure there is adequate horizontal clearance to assemble the full length of the pole.

14. Repeat this process till every segment is assembled in the horizontal position. On each pole segment, tighten the flange bolts in accordance with the standards.

15. Check base for plumb and adjust as necessary.

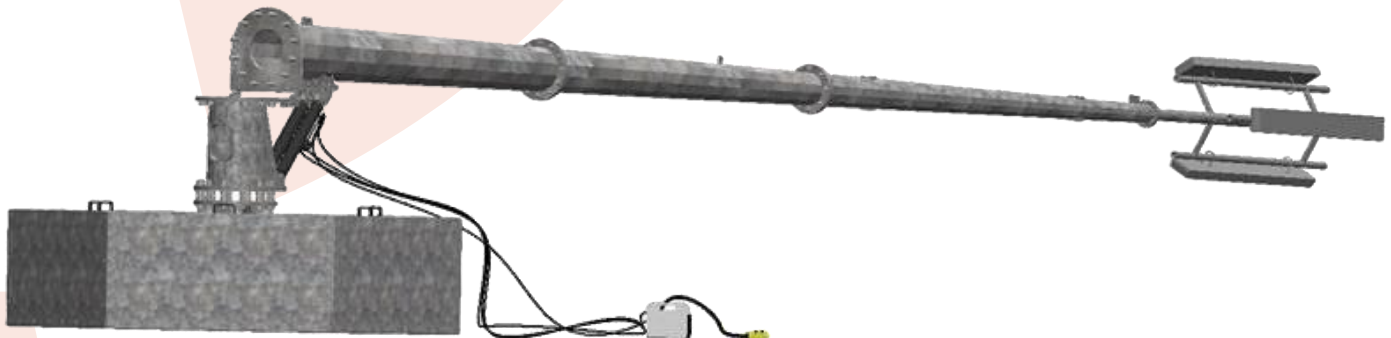

# Lift Assist: (Tilt-Up & Conventional)

**NOTE:** Hydraulic ram or screw-jack should be shipped and received in the retracted (shortest) position. If this is not how it is received you need to hook-up the hydraulic control system of the hydraulic ram (per instructions provided in the system product manual) or work the screw-jack to fully retract the unit prior to moving forward with assembly.

16. Attach the hydraulic ram (upper attachment hole only) or screw-jack.

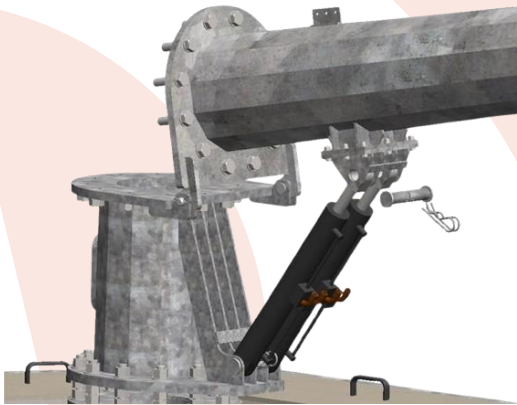

(either attachment hole) to the first pole segment connection using one (1) M64x593 **CYLINDER PIN** and two (2) 12mm Cotter pins as shown (fig).

17. Allow the connected hydraulic ram or screw-jack to pivot and rest at the foundation level.

18. Locate and pre-position first pole section so the section can be lifted into place.

19. Lift the first pole section into position and align with the open hinge on the Kingpost base flange.

20. Use two (2) M64x593 Clevis pins, and two (2) 12mm Cotter pins to complete the hinge between the first pole flange and the Kingpost Base flange.

21. Pre-position one (1) M64x593 Cylinder pin, and two (2) 12mm Cotter pin for easy access prior to starting the next step.

22. Lift/pivot the end of the first pole section upwards to approx. 90° relative to the base.

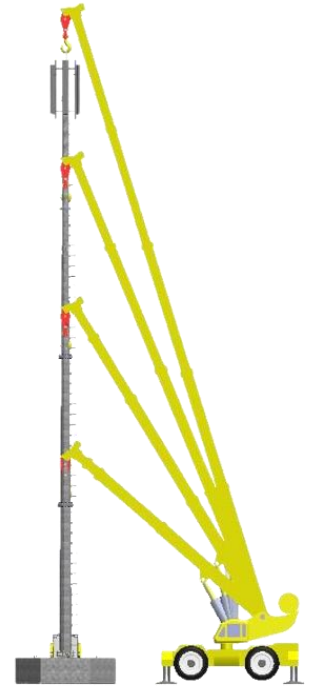

Conventional Monopole

23. Lift/pivot the hydraulic ram or screw-jack upwards to align the hole on the piston head with the hole in the lifting lug located on the side of the first pole section.

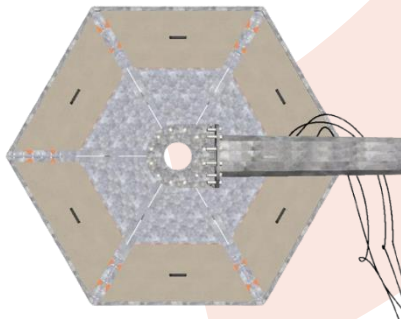

Adjust the free end of the pole section up or down slightly M64x593 to align and pin the connection with the pre-positioned M64x593 Cylinder pin, and 12mm Cotter pins.

In conventional monopole, pole sections and flanges are marked and aligned straight, nut fixing and tightening will be done. The placement of the pole sections are done using crane.



Tilt-Up pole

## Connecting Section:

24. Add M36 hex nut and M36 flat washer to the top of the Kingpost Flange Plate each M36x2.5x225 hex bolts used to assemble the pole segments.

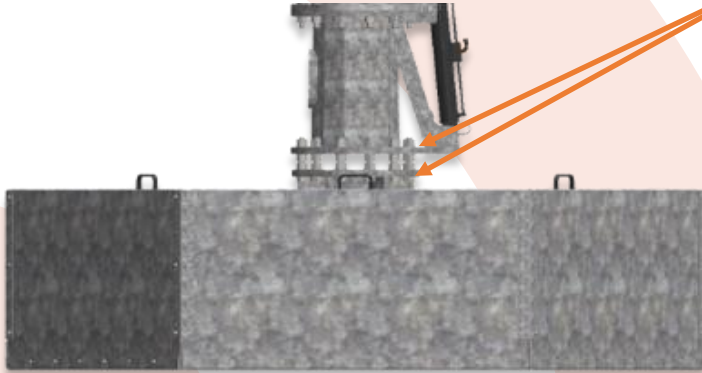

**NOTE:** Leave a consistent 110mm (4.3") gap between pole flange bottom hex nuts and flat washers and the top of the hex nut used to complete base assembly in earlier steps.

25. Connect the hydraulic power unit (12v) power supply following the instructions provided in the 20T Hydraulic Raising System Product Manual.

26. Raise the first pole section to its vertical position using the hydraulic ram or screw-jack. Ensure the system is operating properly without binding or twisting. **DO NOT FORCE IF BINDING OR TWISTING DEVELOPS.**

27. When the first pole is vertical and resting on the flange washers and nuts, check that the pole is plumb. Adjust the flange nuts with an open ended or crescent wrench to bring the pole into plumb. All four washers must touch and support the flange before moving forward with the next step.

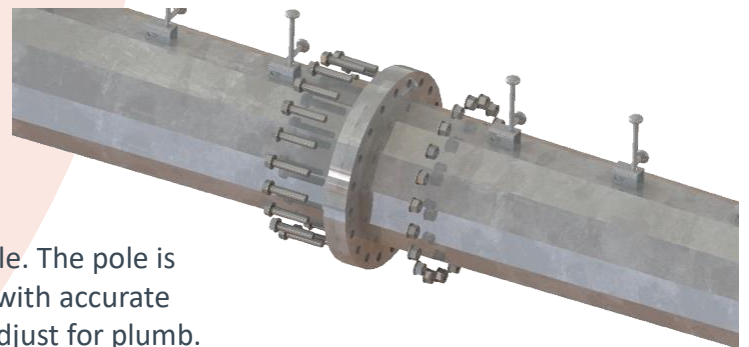

**NOTE:** Do not check plumb using the side(s) of the pole. The pole is tapered from top to bottom and will not provide you with accurate measurements. Use bottom or top flange of pole to adjust for plumb.

28. Once properly adjusted, return the first pole section to the horizontal position using the hydraulic ram or screw-jack. **DO NOT DISCONNECT HYDRAULIC RAM OR SCREW-JACK.**

## Additional Sections

29. Locate and pre-position the (4) remaining pole sections of 50' pole. Each section and flange is marked respectively. Marks on each flange will align with marks on the corresponding flange ensuring the pole will be straight when fully assembled.

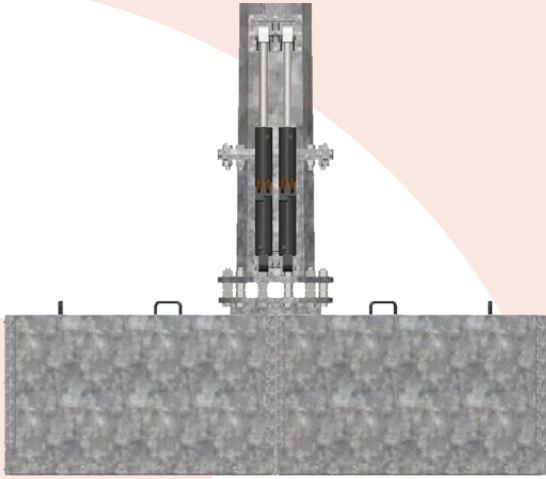

Assemble the Kingpost with the first pole section using (16x)  $\varnothing 22\text{mm}$  hex bolts.

30. Elevate the second pole section horizontally positioned and mark on both upper and lower Flange Plates.

Attach the hydraulic jack or ram to the Cylindrical Bracket of Kingpost attached to the rod end bracket using the (2x) 15-20T hydraulic Cylinder Stroke 20.27" (515mm).

31. Elevate the third pole section into position and secure the upper and lower flanges using (12x)  $\varnothing 22\text{mm}$  hex bolts, (12x) flat washers and hex nuts.

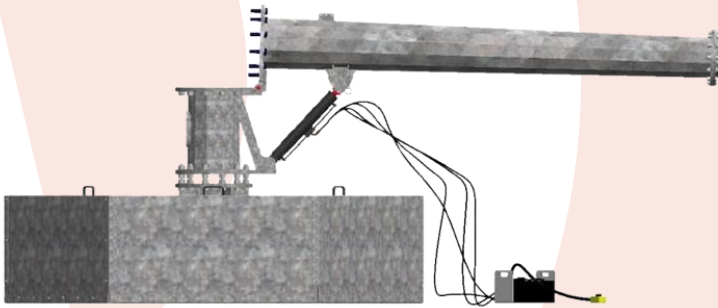

Tighten each bolt to torque specifications provided on Pg. 11 of this installation manual. Add shims as needed per TIA code.

32. Following the above steps elevate till fourth pole sections are positioned accordingly and secure its upper and lower flanges using (8x)  $\varnothing 22\text{mm}$  and (8x)  $\varnothing 22\text{mm}$  hex bolts, flat washers and hex nuts.

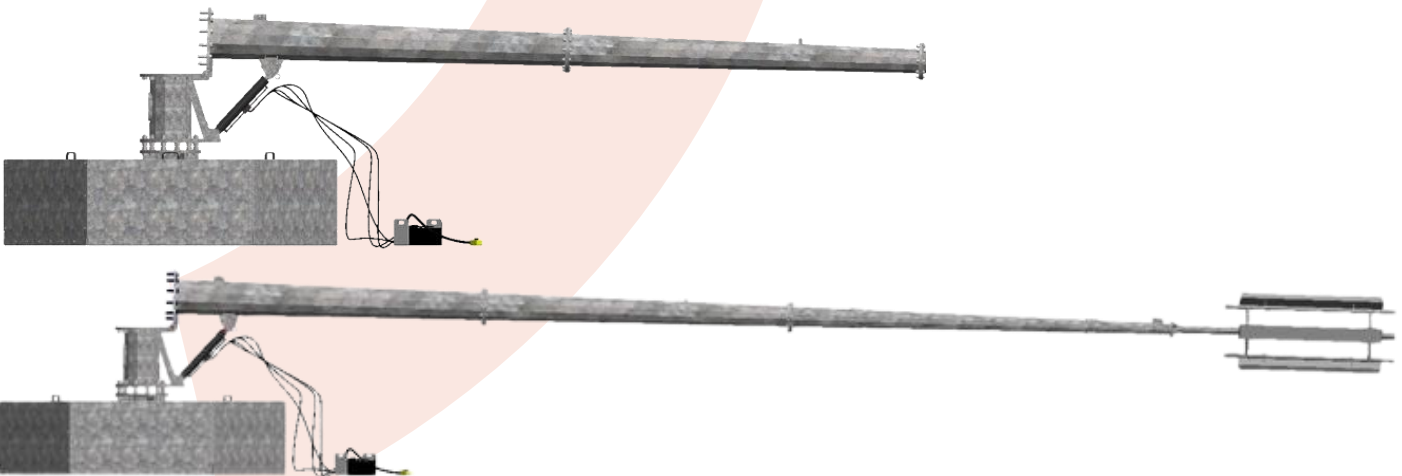

Tighten each bolt to torque specifications provided on Pg. 11 of this installation manual. Add shims as needed per TIA code.

### **NOTE:**

At this point, the pole is stable and ready for any/all accessories or additional equipment to be installed. Combined weight of all equipment, mounting systems, fasteners, cables, etc. shall not exceed the engineered specifications provided and accepted at the time of purchase.

## Raising Completed Tower:

33. Raise the completed tower into the vertical position using the hydraulic ram or screw-jack. The tower should return to the same position established in step #32 when adjusting for plumb.

34. Add (16x)  $\varnothing 22\text{mm}$  bolts, (16x) hex nut & (16x) flat washers to the first pole segment with the corresponding elevated pole segment.



Tighten each bolt to torque specifications provided on Pg. 11 of this installation manual.

## Removing Raising System:

**NOTE:** Raising systems are not weather proof and should be removed and stored after installation. Use care and caution when removing the hydraulic ram or screw-jack from the tower.

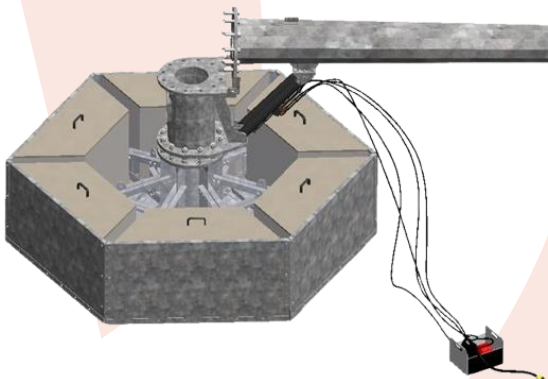

35. After all base flange nuts have been torqued to specifications, adjust the hydraulic ram or screw-jack to create a small amount of slack in the upper and/or lower connection points.

Remove one of the lower Cotter pins and then the Cylinder pin.

(It may be necessary to remove the second Cotter pin and then forcefully drive the Cylinder pin out of the hole if tension cannot be released by adjusting the hydraulic ram or screw-jack.)

Repeat the same procedure to remove the upper Cotters and Cylinder pin.

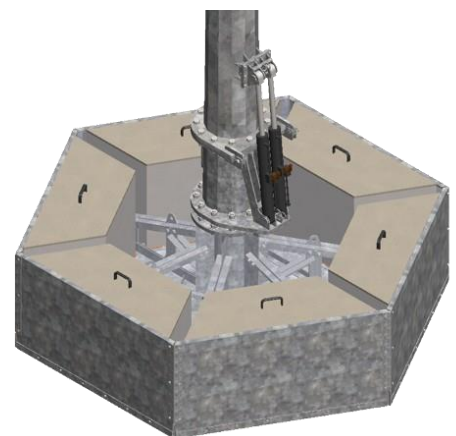

# Torque Specifications

## Recommended Bolt Torque for Anchor Bolts:

Bolt Size (mm)	Width Across Flats (mm)	Net Area (mm <sup>2</sup> )	Yield Stress (MPa)	Tension Force (N)	Recommend Torque (N*m)	Pretension Force (N)
20	30	245	355 (45#)	86904	174	43452
24	36	353	355 (45#)	125138	300	62569
27	41	459	355 (45#)	163087	440	81544
30	46	561	355 (45#)	199013	597	99507
33	50	694	380 (GR55)	263720	870	131860
36	55	817	355 (45#)	289929	1044	144964
42	65	1121	355 (45#)	397955	1671	198978
48	75	1473	355 (45#)	522915	2510	261458
56	85	2030	355 (45#)	720650	4036	360325

## Recommended Bolt Torque for Grade 8.8 Connection Bolts:

Bolt Size (mm)	Width Across Flats (mm)	Net Area (mm <sup>2</sup> )	Yield Stress (MPa)	Tension Force (N)	Recommend Torque (N*m)	Pretension Force (N)
10	16	58	640 (8.8)	37120	37	18560
12	18	84	640 (8.8)	53952	65	26976
16	24	157	640 (8.8)	100480	161	50240
20	30	245	640 (8.8)	156672	313	78336
24	36	353	640 (8.8)	225600	541	112800
27	41	459	640 (8.8)	294016	794	147008
30	46	561	640 (8.8)	353784	1076	179392
33	50	694	640 (8.8)	444160	1466	222080
36	55	817	640 (8.8)	522688	1882	261344
42	65	1121	640 (8.8)	717440	3013	358720
48	75	1473	640 (8.8)	942720	4525	471360
56	85	2030	640 (8.8)	1299200	7276	649600



1041 Grand Avenue #213  
St. Paul, MN 55105  
651-330-1263

Proprietary rights are included in the information disclosed herein. This information is submitted in confidence and neither the document nor the information disclosed here-in shall be reproduced or transferred to other documents for manufacturing or for any other purpose except as specifically authorized in writing by ARE Structures.